

**POWERSWITCH**  
**Semiconductor Relay / - Contactor**  
**With Load Current Measurement PH 9270/003**

Preliminary datasheet



0265817



Semiconductor relay  
PH 9270.91/003

Semiconductor contactor  
PH 9270.91/003/02

**Your Advantages**

- Free from wearing, noiseless, economic
- High productivity by integrated monitoring functions
- Accurate AC / DC measurement up to 45 A
- Analogue output for easy working with signals to PLC or displays
- excellent EMC- performance, because of switching at zero crossing
- As option protection against thermal overload

**Features**

- AC semiconductor relay /-contactor with load current measurement (runs value)
- Analogue output DC 0 ... 10 V
- According to IEC/EN 60947-4-3
- Nominal voltage up to AC 240 V
- Load current up to 45 A, AC-51
- Switching at zero crossing
- DCB technology (direct bonding method) for excellent heat transmission properties
- LED indicator for control
- As option with optimized heat sink, for DIN rail mounting
- Width: 45 mm

**Function Diagram**

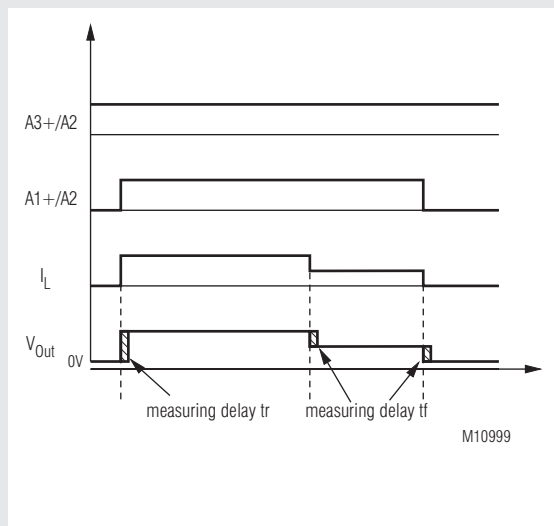

**Approvals and Markings**



**Applications**

The semiconductor relay switches at zero crossing and with its analogue output 0 ... 10 V. It is suitable for heating applications where failures must be detected as early as possible. It allows a continuous monitoring of the load circuit and offers many solutions where fast and silent switching actions are required e.g. in plastic molding and rubber processing machines as well as in thermal forming and packaging machines and also in food industry.

**Circuit Diagram**

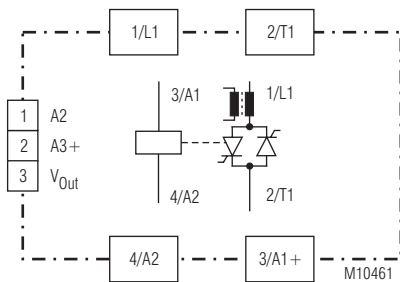

PH 9270.91/003 DC 0 ... 10 V

**Function**

When voltage is applied to A3+/A2 the semiconductor relay PH 9270 monitors continuously the load current and transmits it to a proportional analogue output signal of either 0 ... 10 V. This signal can be easily monitored by a PLC or display module with analogue input.

The PH 9270 with 2 antiparallel connected thyristors switches at zero crossing. When connecting the control voltage the semiconductor is switched on with the next zero crossing of the sinusoidal voltage. After disconnecting the control voltage the semiconductor switches off with the next zero crossing of the load current.

As option the PH 9270 is available with heat sink for DIN rail mounting and immediately "ready to use". In addition the heat dissipation is optimised.

**Indication**

The LED „A1/A2“ shows the state of the control input  
 yellow: controlled semiconductor relays  
 off: not controlled semiconductor relays

## Notes

### Overtemperature protection

As option, the semiconductor relay has an overtemperature protection to monitor the temperature of the heat sink. For this purpose, a thermal switch (NC contact) can be inserted into the respective pocket at the bottom of the semiconductor relay. As soon as the temperature of the heat sink exceeds for example 100°C, the thermal switch opens. For thermal protection of the semiconductor relay, a thermal switch of *UCHIYA* type UP62 – 100 can be installed.

## Technical Data

### Output

Load voltage AC [V]:	24 ... 240
Frequency range [Hz]:	47 ... 63
Load current measuring range [A], (AC-51):	25            45
Min. load current [A]:	0.02
Load limit integral I <sup>2</sup> t [A <sup>2</sup> s]:	1800; 6600 <sup>*)</sup>
Max. overload current [A] t = 10 ms:	600; 1150 <sup>*)</sup>
Period. overload current [A] t = 1 s:	120; 150 <sup>*)</sup>
Forward-voltage [V] at nominal current:	1.2            1.4
Peak reverse voltage [V]:	800
Off-state voltage [V/μs]:	500
Rate of rise of current [A/μs]:	100
Residual current at off state at nominal voltage and nominal frequency [mA]:	≤ 1

### Temperature Data

Thermal resistance junction - housing [K/W]:	0.6            0.5
Thermal resistance housing - ambient [K/W]:	12
Junction temperature [°C]:	≤ 125

<sup>\*)</sup> variant /1\_ \_

### Control Circuit

Control voltage A1+/A2:	20 ... 32 V DC
Max. input current [mA]:	10 at 24 V DC

### Analogue output 0 ... 10 V

Operation voltage A3+/A2:	18 ... 32 V DC
Min. input current [mA]:	5 (dependent to load on analogue output)
Output voltage V <sub>out</sub> :	10 V equivalent of measuring range (e.g. 25 A)
Min. load resistance [Ω]:	300
Min. measuring current:	1 % of measuring range
Delay of measurement t <sub>r</sub> [ms]:	< 120
Delay of measurement t <sub>f</sub> [ms]:	< 300
Measuring accuracy:	± 2 % of measuring range (nominal current)
Max. cable length [m]:	10 (twisted and shielded)

### General Data

<b>Operating mode:</b>	Continuous operation	
<b>Temperature range</b>		
operation:	- 20 ... 40° C	
storage:	- 20 ... 80° C	
<b>Clearance and creepage distances:</b>		
rated impulse voltage / pollution degree:	6 kV / 3	IEC/EN 60 664-1
<b>EMC:</b>	IEC/EN 61 000-6-4,	IEC/EN 61 000-4-1
Electrostatic discharge (ESD):	8 kV air / 6 kV contact	IEC/EN 61 000-4-2
HF irradiation:	10 V / m	IEC/EN 61 000-4-3
Fast transients:	2 kV	IEC/EN 61 000-4-4
Surge voltages between		
wires for power supply L1, T1:	1 kV	IEC/EN 61 000-4-5
wires A1, A2 and ground:	1 kV	IEC/EN 61 000-4-5
measuring output and ground:	1 kV	IEC/EN 61 000-4-5
wires L1, T1 and ground:	2 kV	IEC/EN 61 000-4-5
HF-wire guided:	10 V	IEC/EN 61 000-4-6
Interference suppression:	Limit value class A	IEC/EN 60 947-4-3

## Technical Data

### Degree of protection

Housing:	IP 40	IEC/EN 60 529
Terminals:	IP 20	IEC/EN 60 529

### Vibration resistance:

Amplitude	0.35 mm
Frequency	10 ... 55 Hz, IEC/EN 60-068-2-6

### Housing material

Fiberglass reinforced polycarbonate  
Flame resistant: UL 94 V0

### Base plate:

Aluminum, copper nickle-plated

### Potting compound:

Polyurethane

### Mounting screws:

M 5 x 8 mm

### Mounting torque:

2.5 Nm

### Connections control circuit:

Mounting screws M3 Pozidriv 1 PT

### Mounting torque:

0.5 Nm

### Wire cross section:

1.5 mm<sup>2</sup> Litze

### Anschlüsse Lastkreis:

Mounting screws M4 Pozidriv 2 PT

### Mounting torque:

1.2 Nm

### Wire cross section:

10 mm<sup>2</sup> Litze

### Connections

### monitoring circuit:

Weidmüller - Omnimate Range  
connecting pair BL 3.50/03  
(included in delivery)

### Nominal insulation voltage

Control circuit – load circuit: 4 kV<sub>eff.</sub>

Load circuit – base plate: 4 kV<sub>eff.</sub>

### Overvoltage category:

II

### Weight

without heat sink: approx. 110 g

PH 9270.91/\_/\_/\_/01: approx. 540 g

PH 9270.91/\_/\_/\_/02: approx. 650 g

### Dimensions

#### Width x height x depth

without heat sink: 45 x 59 x 32 mm

PH 9270.91/\_/\_/\_/01: 45 x 80 x 124 mm

PH 9270.91/\_/\_/\_/02: 45 x 100 x 124 mm

### Dimensions

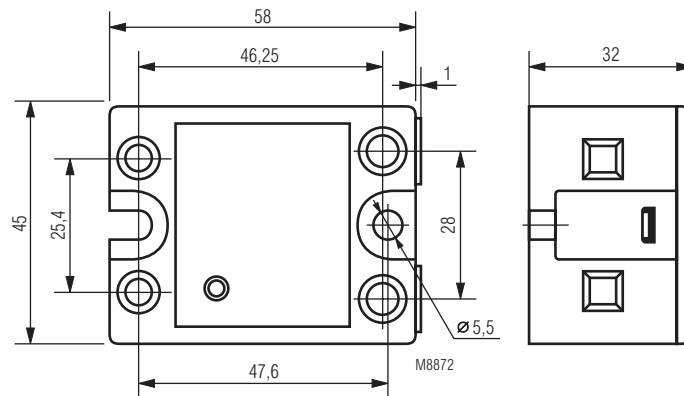

### Accessories

PH 9260-0-12: Graphite foil 55 x 40 x 0.25 mm to be fitted between device and heat sink, for better heat transmission. Article number: 0058395

### Notes on Sizing for Selection of a Heat Sink

The heat generated by the load current must be dissipated by a suitable heat sink. It is imperative that the junction temperature of the semiconductor is maintained for all potential environmental temperatures of under 125°C. For this reason, it is important to keep the thermal resistance between the base plate of the semiconductor relay and the heat sink to a minimum.

To protect the semiconductor relay effectively from excess heating, a thermally conducting paste or a graphite gasket (see Accessories) should be applied before installation to the base plate of the heat sink between semiconductor relay and heat sink.

From the table below, select a suitable heat sink with the next lowest thermal resistance. Thus, it is ensured that the maximum junction temperature of 125°C is not exceeded. The load current in relation to the environmental temperature can be seen from the table.

### Selection of a Heat Sink

Load current (A)	PH 9270 25 A					
	Thermal resistance (K/W)					
25.0	2.8	2.5	2.1	1.8	1.5	1.1
22.5	3.2	2.8	2.5	2.1	1.7	1.3
20.0	3.7	3.3	2.8	2.4	2.0	1.6
17.5	4.3	3.8	3.4	2.8	2.4	1.9
15.0	5.1	4.6	4.0	3.5	2.9	2.4
12.5	6.3	5.6	5.0	4.3	3.6	2.8
10.0	8.0	7.2	6.4	5.6	4.7	3.9
7.5	11.0	9.9	8.7	7.6	6.5	5.4
5.0	16.8	15.0	13.5	12.0	10.0	8.5
2.5	-	-	-	-	21.0	17.6
	20	30	40	50	60	70
	Ambient-temperature (°C)					

Load current (A)	PH 9270 45 A					
	Thermal resistance (K/W)					
45	1.0	0.9	0.7	0.5	0.4	0.2
40	1.2	1.0	0.9	0.7	0.5	0.3
35	1.5	1.3	1.0	0.9	0.7	0.5
30	1.9	1.6	1.4	1.1	0.9	0.7
25	2.4	2.0	1.8	1.5	1.2	0.9
20	3.0	2.7	2.4	2.0	1.9	1.3
15	4.4	3.9	3.4	2.9	2.5	2.0
10	6.9	6.0	5.4	4.7	4.0	3.3
5	14.0	12.9	11.5	10.0	8.6	7.2
	20	30	40	50	60	70
	Ambient-temperature (°C)					

### Standard Type

PH 9270.91/003 AC 24 ... 240 V 25 A DC 0 ... 10 V  
 Article number: 0062432  
 • Load voltage: AC 24 ... 240 V  
 • Load current / measuring range: 25 A  
 • Analogue output: DC 0 ... 10 V  
 • Width: 45 mm

### Variants

PH 9270.91 / \_ 0 3 / 0 \_  
 0 = without heat sink  
 1 = with heat sink 1.5 K / W  
 2 = with heat sink 0.95 K / W  
 0 Standard  
 1 With high I<sup>2</sup>t-value

### Ordering example for variants

PH 9270.91 /103/02 AC 24 ...240 V 25 A DC 0 ... 10 V  
 Analogue output  
 Load current  
 Load voltage  
 With heat sink 0.95 K / W  
 With high I<sup>2</sup>t-value  
 Type

### Application Example

